

Cobalt 14

Underwater Connectors



Features

- Larger version of the highly popular Cobalt series of dry-mate underwater connectors and cables
- Bulkhead connector fits in 14-mm hole
- Ideal for autonomous vehicles, underwater instruments, and other extreme-environment applications
- Submersible up to 600 meters
- Corrosion-resistant, durable 316 stainless steel and PEEK materials
- 3-pin, 4-pin, and 10-pin Hybrid versions
- Up to 35 amps per pin
- Compatible with Blue Robotics T500 thruster
- Cable Termination Kit allows users to install Cobalt 14 connectors on their own cables
- Stocked and ready to ship in 2-3 days

Description

The Cobalt 14 series of underwater connectors expands the Cobalt line with a larger shell size, offering higher current-carrying capability while delivering the same reliability and affordability that has made the Cobalt line so popular.

Featuring 316 stainless steel shells and PEEK inserts, Cobalt 14 connectors withstand long-term use in seawater at depths up to 600 meters. Connector shells are keyed and feature a scoop-proof design, allowing them to be mated blind with no possibility of pin damage.

The Cobalt 14 bulkhead connector, which fits in a 14-mm hole, is available in 3-pin, 4-pin, and 10-pin Hybrid power/signal versions. Matching Cobalt 14 Cable Termination Kits allow users to install Cobalt 14 connectors directly onto their own cables without having to use bulky and time-consuming splices.

Advantages

Cost

Cobalt 14 connectors achieve a hermetic seal without the need for potting or overmolding. The electrical contacts are pressed into a machined PEEK insert, which is in turn pressed into the stainless steel connector shell. This simple design makes Cobalt 14 connectors more affordable than traditional molded connectors.

Reliability

In addition to reducing cost, the unique design of Cobalt 14 connectors increases their reliability. Without a bonded rubber overmold, there is no danger of leakage due to cathodic delamination. A simple, proven O-ring seal between the male and female connectors makes Cobalt connectors both easier to use and more reliable than wet-mate connectors.

Availability

Stock connectors and typically ship in 2-3 days. Custom items or large orders ship in 1-2 weeks.

Options

Cobalt 14 bulkhead connectors and cable termination kits are available in 3-pin, 4-pin, and 10-pin Hybrid versions and are suitable for data, power, or combined power/signal applications.

Compatibility

Cable Termination Kits allow users to retrofit any existing cable with a Cobalt 14 connector, provided that the cable has a bondable jacket material (typically polyurethane or neoprene) and a diameter smaller than 11.0 mm. Cable Termination Kits include the connector shell, PEEK insert with pre-installed sockets, and locking sleeve. The user solders the cable wires to the insert, presses the insert into the connector shell, and pots the back of the connector shell with epoxy.

The Cobalt 14 bulkhead connector fits in the same hole as the 14-mm Blue Robotics WetLink penetrator, making quick-connect and quick-disconnect possible with the Blue Robotics T500 thruster.

Specifications

Environmental	
Depth Rating	600 meters
Operating Temperature	0° C to +50° C
Electrical	
Rated voltage and current	3-pin: 400 VDC, 35 amps per pin 4-pin: 400 VDC, 35 amps per pin 10-pin Hybrid: 150 VDC, 2x 35 amps per pin, 8x 3 amps per pin
Bulkhead wire size and stranding	3-pin: 12 AWG, 37/28 4-pin: 12 AWG, 37/28 10-pin Hybrid: 2x 12 AWG, 37/28; 8x 24 AWG, 7/32
Bulkhead wire configuration	3-pin: unshielded, untwisted 4-pin: unshielded, untwisted 10-pin Hybrid: 2x unshielded, untwisted; 8x Cat 5e
Materials	
Bulkhead shell	316 stainless steel
Bulkhead insert	PEEK
Bulkhead pins	gold-plated brass
Cable Termination Kit shell	316 stainless steel
Cable Termination Kit insert	PEEK
Cable Termination Kit sockets	gold-plated brass
Wire insulation	3-pin: ETFE 4-pin: ETFE 10-pin Hybrid: ETFE, polyolefin
O-rings	nitrile
Locking sleeve	acetal
Dimensions	
Bulkhead threads	M14 X 1.5
Bulkhead hex	20 mm
Locking sleeve threads	M20 X 1.5

Dimensions*

Bulkhead dimensions

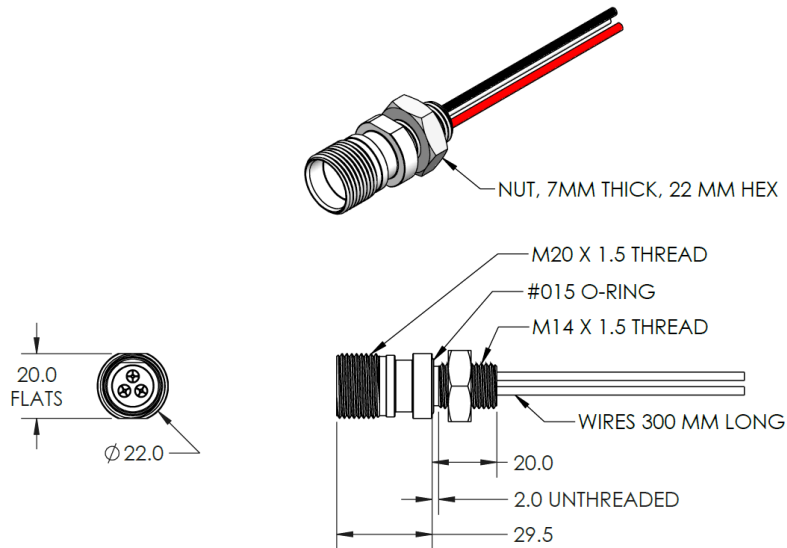

Cable Termination Kit dimensions

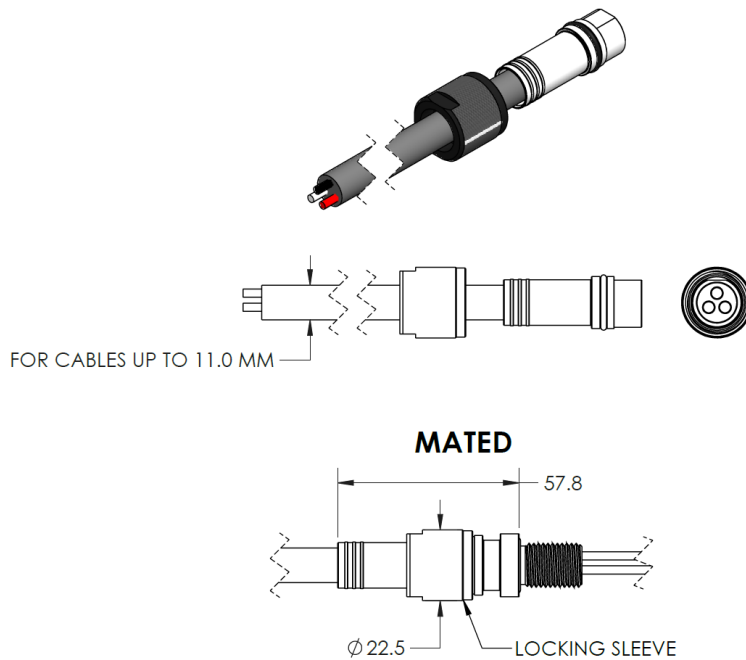



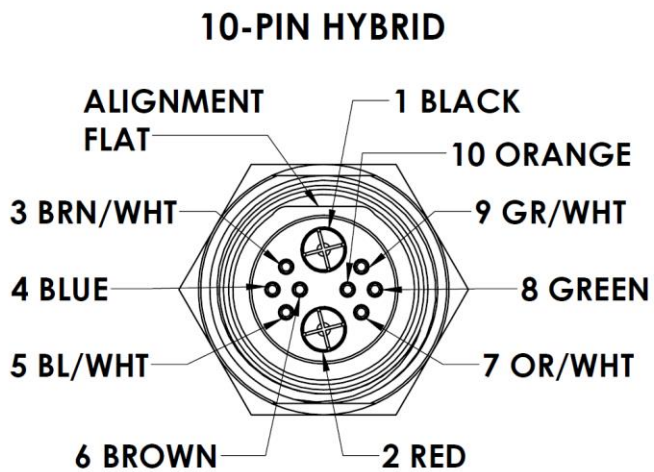
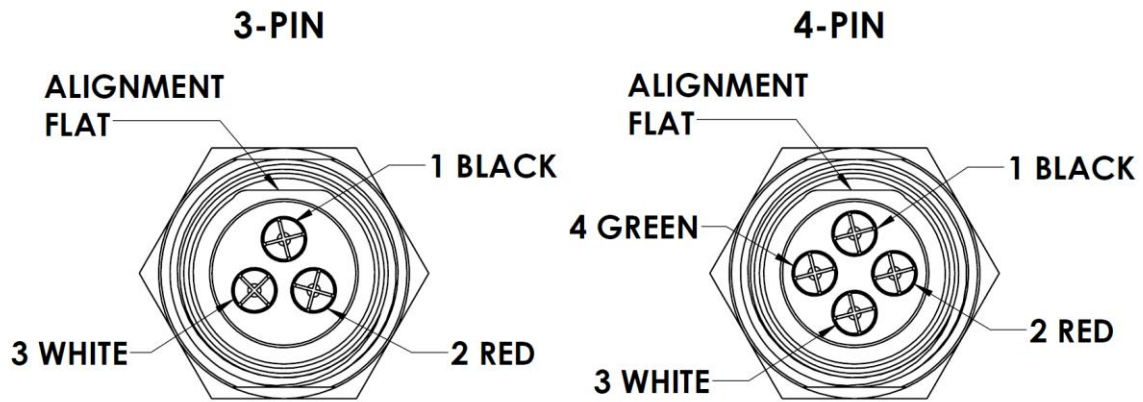

*Contact Blue Trail Engineering for CAD models

Pinouts

Bulkhead connector pinouts (looking at mating face of connector)

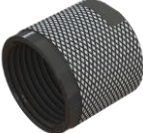

Configurations and Part Numbers

<p>Bulkhead Connector: C14-11N0 <u>N</u>: number of pins (3, 4, or 10H)</p> 	<ul style="list-style-type: none"> • Corrosion-resistant 316 stainless steel bulkhead connector • Threaded shank M14 X 1.5 • Includes stainless steel nut
<p>Cable Termination Kit: C14-31N0 <u>N</u>: number of pins (3, 4, or 10H)</p> 	<ul style="list-style-type: none"> • Used to terminate an existing cable with a Cobalt 14 connector • Requires potting connector shell with epoxy • Corrosion-free 316 stainless steel connector shell, PEEK insert with pre-installed sockets, acetal locking sleeve, and O-ring
<p style="text-align: center;">Accessories</p> <p>Locking Sleeve: C14-1001</p>  <p>Dummy Plug: C14-1002</p> 	<ul style="list-style-type: none"> • Locking sleeve used to hold dummy plug in place • Dummy plug seals and protects an unused bulkhead connector